

PICO GATEWAY PLAZA

9444 E. Whittier Boulevard, Pico Rivera, CA 90660

FEATURES:

- Frontage on Whittier Blvd.
 - Approximately 880 S.F. with glass storefront
 - Abundant parking spaces
 - Rooftop A/C
 - Easy access to 605/5 Freeway
- (All measurements are approximate)

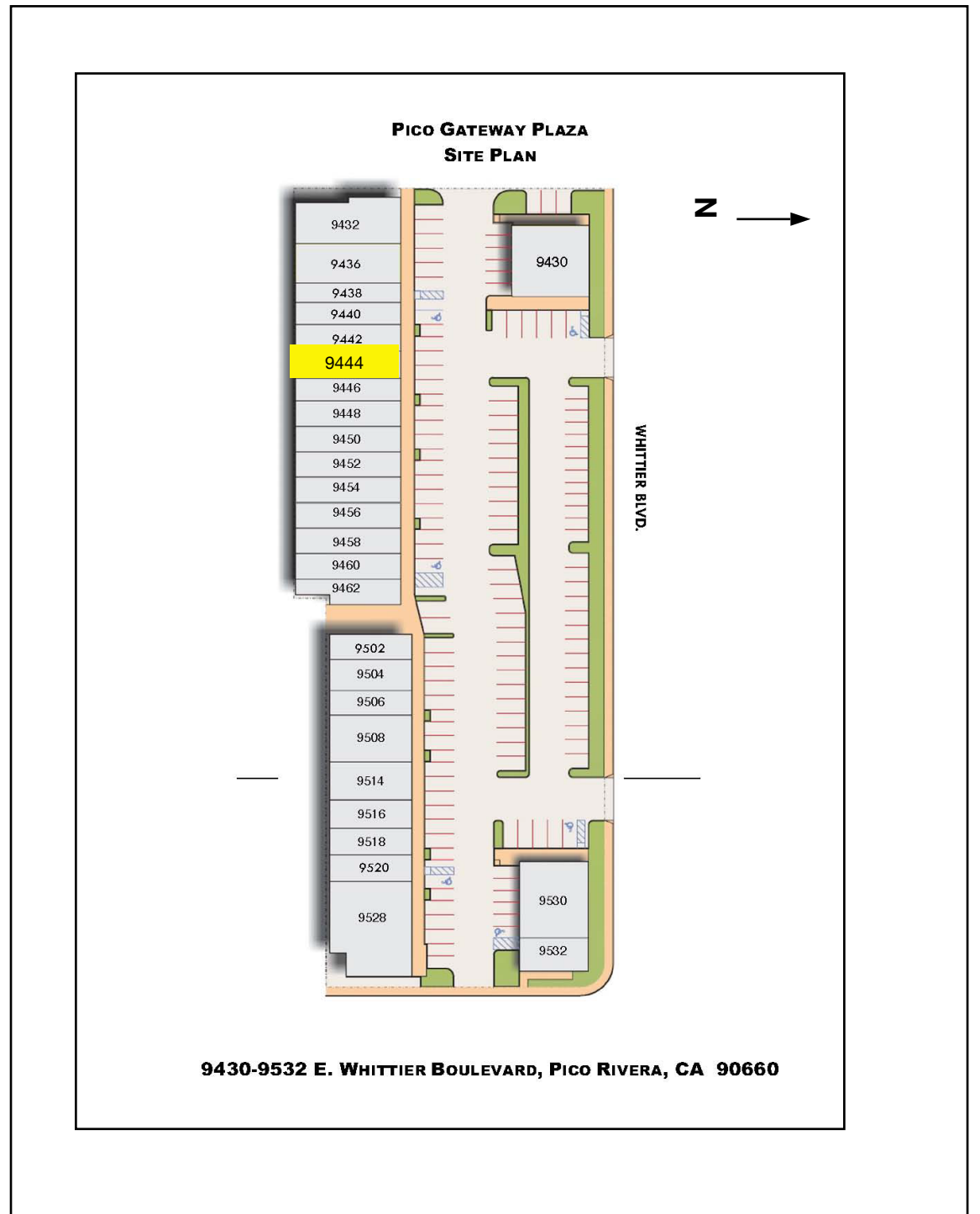
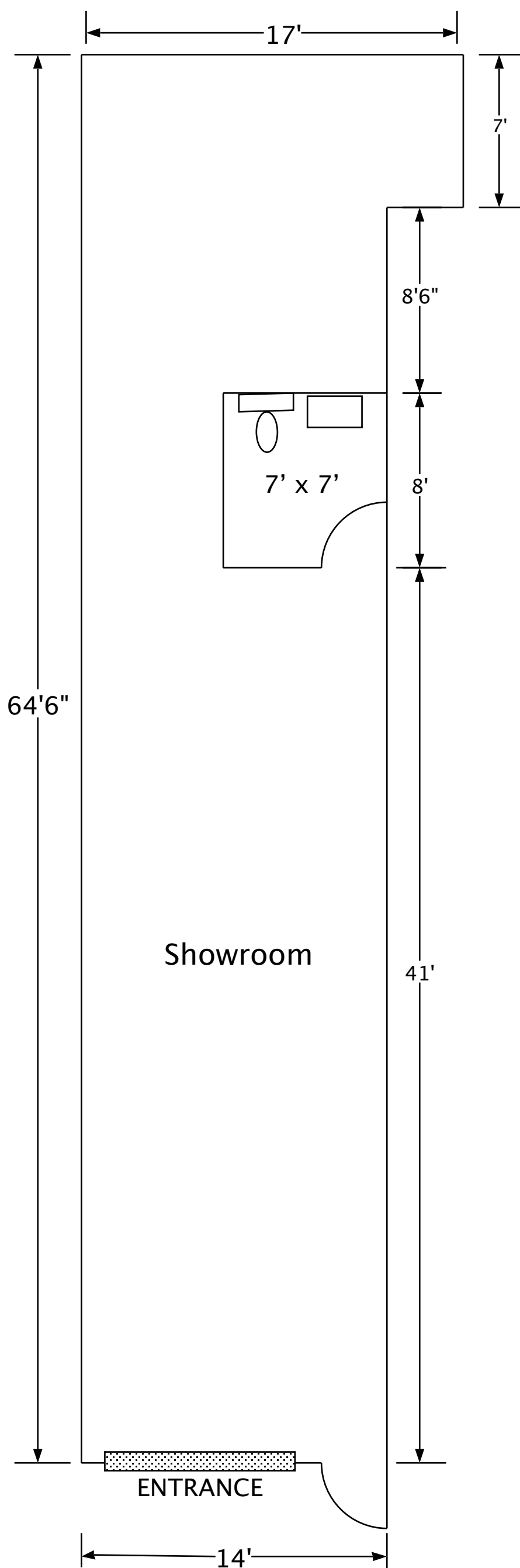

Contact: (714)997-7956 ext.113 for Don or 105 for Damian

S&D ASSOCIATES LEASING OFFICE: 1020 N. BATAVIA ST. STE. B, ORANGE, CA 92867

TEL 714/997-7956 • FAX 714/997-4930 • Leasing@SDAssociatesProperties.com